

OWNER'S MANUAL

HOLIST

RS-1501 SHOULDER PRESS

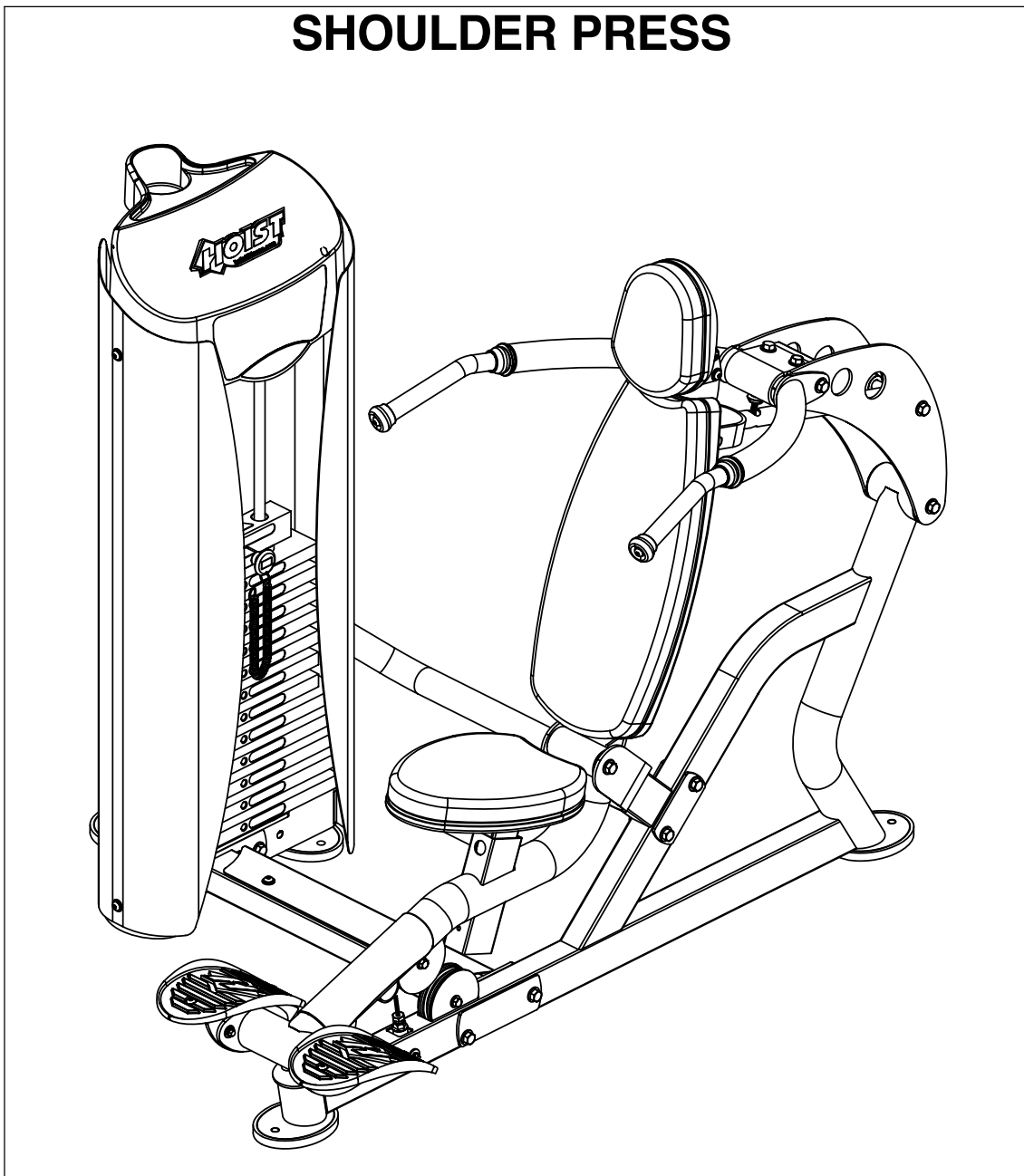

Note: Both Serial Number and Model Number are Required when Ordering Parts

RECORD SERIAL NUMBER HERE

CATALOG NUMBER

0406 - 015

Customer Service

(800) 548-5438

(858) 578-7676

Fax

(858) 578-9558

OWNER'S MANUAL

CONTENTS

INSTRUCTIONS	02
FRAME ASSEMBLY	04
PRE-ASSEMBLY.....	14
DECAL PLACEMENT.....	15
DECAL REFERENCE.....	16
PART LIST.....	17
ABBREVIATIONS.....	19
BOLT SIZING CHART.....	20
WASHER SIZING CHART.....	22
MAINTENANCE SCHEDULE.....	24
GENERAL MAINTENANCE INFORMATION.....	25
WEIGHT TRAINING TIPS.....	28
WEIGHT RATIOS.....	29
EXERCISE LOG.....	30
LIMITED WARRANTY.....	31

OWNER'S MANUAL

INSTRUCTIONS

Before beginning assembly please take the time to read instructions thoroughly. Please use the various lists in this manual to make sure that all parts have been included in your shipment. When ordering, use part number and description from the lists. Use only HOIST replacement parts when servicing. Failure to do so will void your warranty and could result in personal injury.

HOIST equipment is designed to provide the smoothest, most effective exercise motion possible. After assembly, you should check all functions to ensure correct operation. If you experience problems, first recheck the assembly instructions to locate any possible errors made during assembly. If you are unable to correct the problem, call your authorized HOIST dealer. Be sure to have your serial number and this manual when calling. When all parts have been accounted for, continue on.

TOOLS REQUIRED

Ratchet Wrench

1/2", 9/16" and 3/4" Sockets

Adjustable Wrench

Rubber Mallet

Tape Measure

Level

Hex Key Wrench Set

OWNER'S MANUAL

THIS PAGE WAS INTENTIONALLY LEFT BLANK

OWNER'S MANUAL

FRAME ASSEMBLY

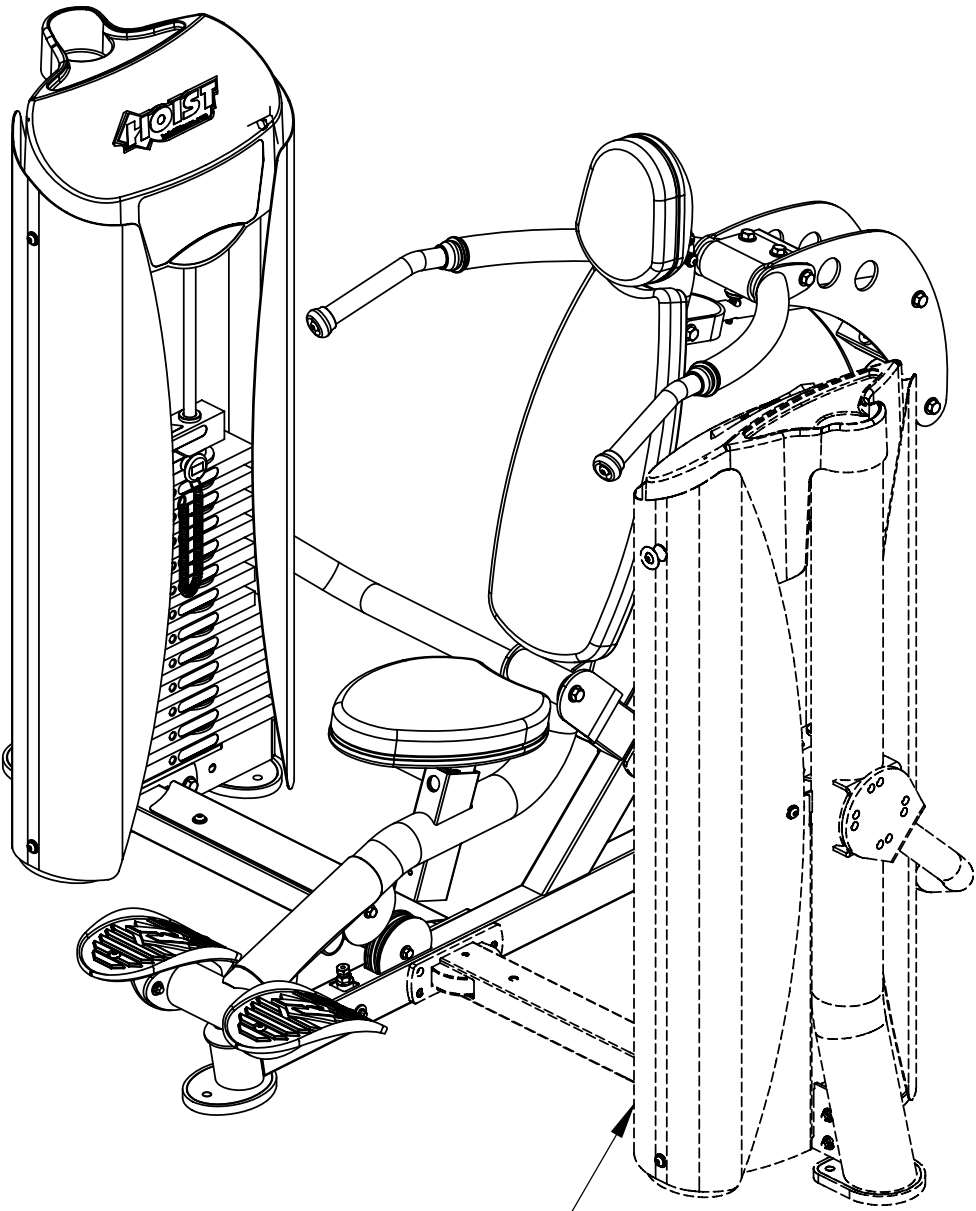

ALTERNATIVE WIEGHT CAGE POSITION

ALTERNATE POSITION

THE ROC-IT WEIGHT CAGE IS DESIGNED TO BE INSTALLED ON EITHER THE LEFT OR RIGHT SIDE OF THE RS-1501 IN ORDER TO ACCOMADATE THE USER.

OWNER'S MANUAL

FRAME ASSEMBLY

ASSEMBLE WEIGHT CAGE FIRST

NOTE:
- WRENCH TIGHTEN HARDWARE.
- SOME PARTS MAY HAVE BEEN REMOVED FOR CLARITY.

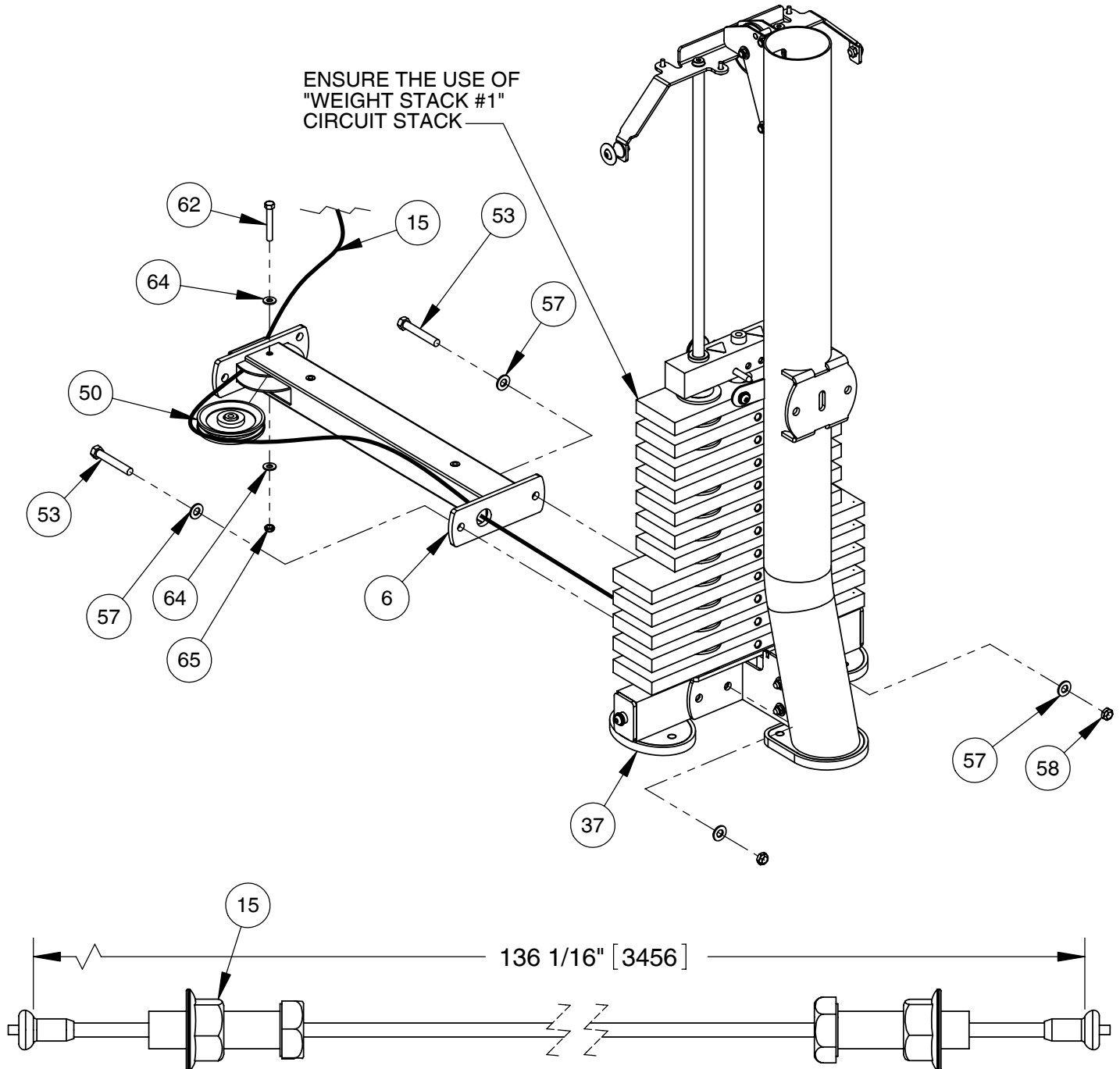

OWNER'S MANUAL

FRAME ASSEMBLY

NOTE:

- WRENCH TIGHTEN HARDWARE.
- HAND TIGHTEN HARDWARE.
- WRENCH TIGHTEN ALL HARDWARE FROM PREVIOUS STEPS.
- SOME PARTS MAY HAVE BEEN REMOVED FOR CLARITY.

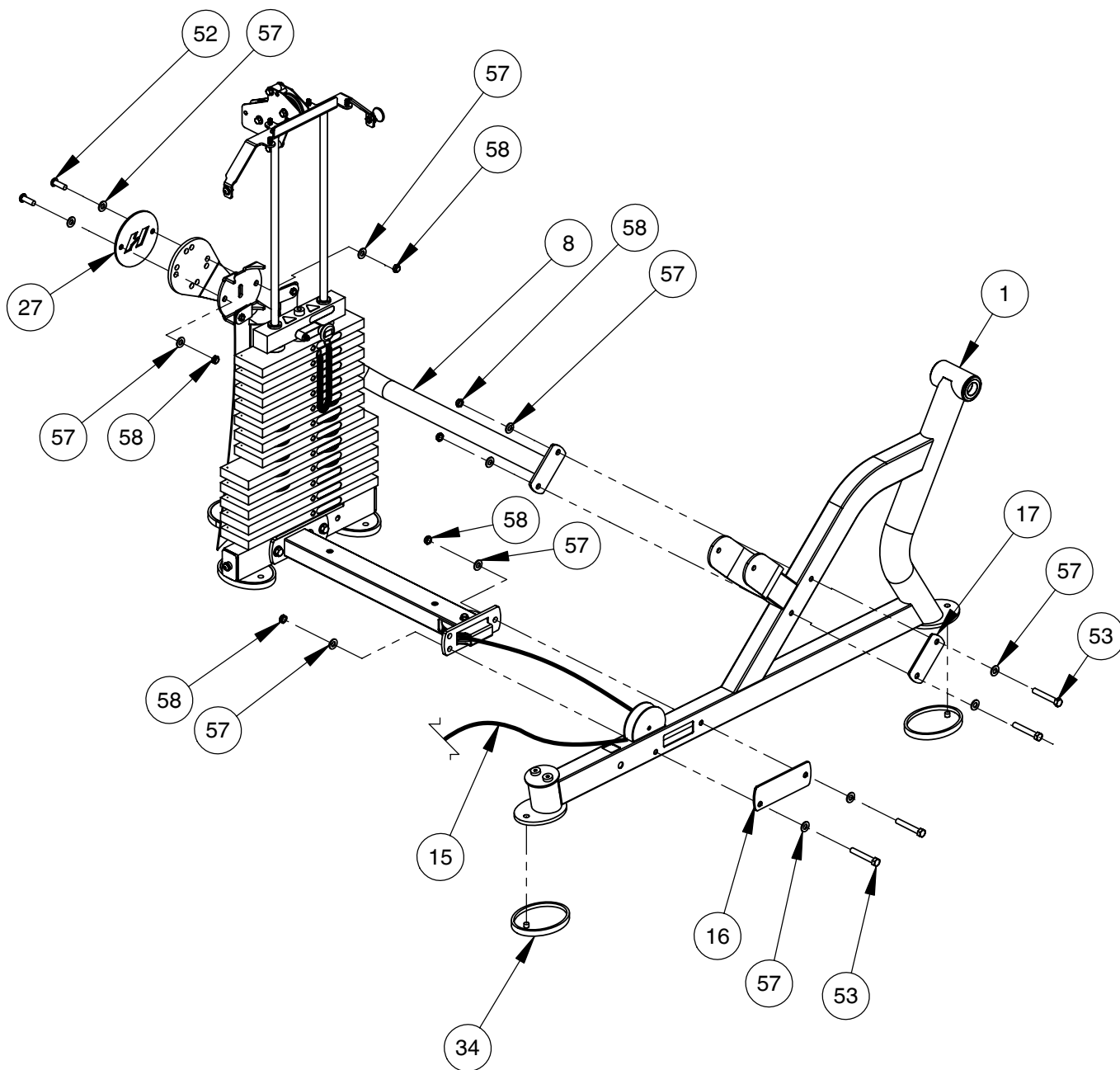

OWNER'S MANUAL

FRAME ASSEMBLY

- NOTE:
- WRENCH TIGHTEN HARDWARE (55 & 60) THEN LOOSEN NUT JUST ENOUGH FOR(2 & 50) TO PIVOT FREELY.
 - WRENCH TIGHTEN ALL OTHER HARDWARE.
 - WRENCH TIGHTEN ALL HARDWARE FROM PREVIOUS STEPS.
 - SOME PARTS MAY HAVE BEEN REMOVED FOR CLARITY.

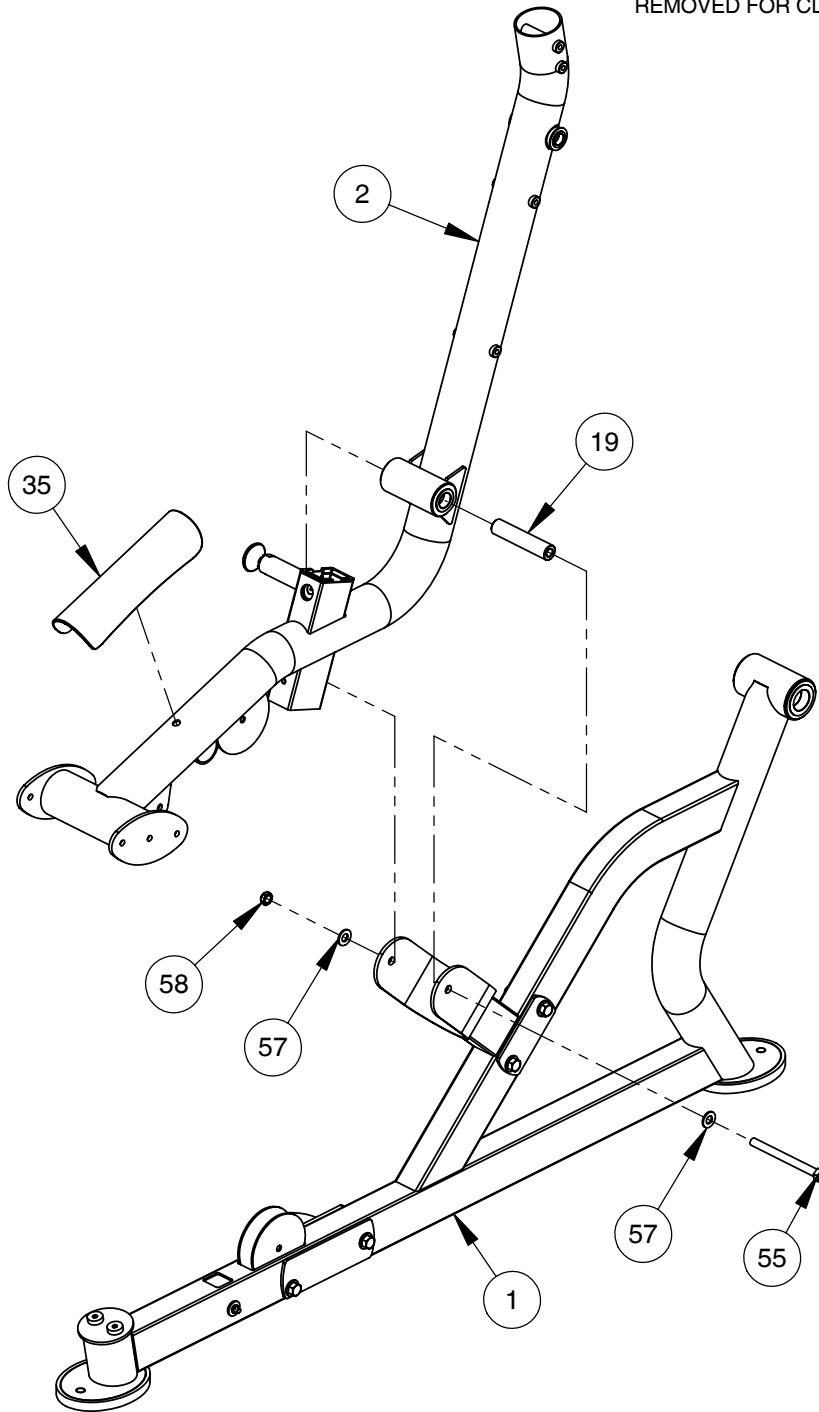

OWNER'S MANUAL

FRAME ASSEMBLY

LIGHT CABLING OPTION

WARNING - CABLE BOLT MUST BE THREADED A MINIMUM OF 3/8" WITH JAM NUT TIGHTENED SECURELY TO ENSURE PROPER CONNECTION.

NOTE:

- WRENCH TIGHTEN ALL OTHER HARDWARE.
- INSTALL **CABLE** AND PULLEYS AT THE SAME TIME.
- SOME PARTS MAY HAVE BEEN REMOVED FOR CLARITY.

FINE TUNING:

LOOSEN JAM NUT AND THREAD BOLT IN/OUT TO GIVE THE **CABLE** PROPER TENSION. RE-TIGHTEN JAM NUT.

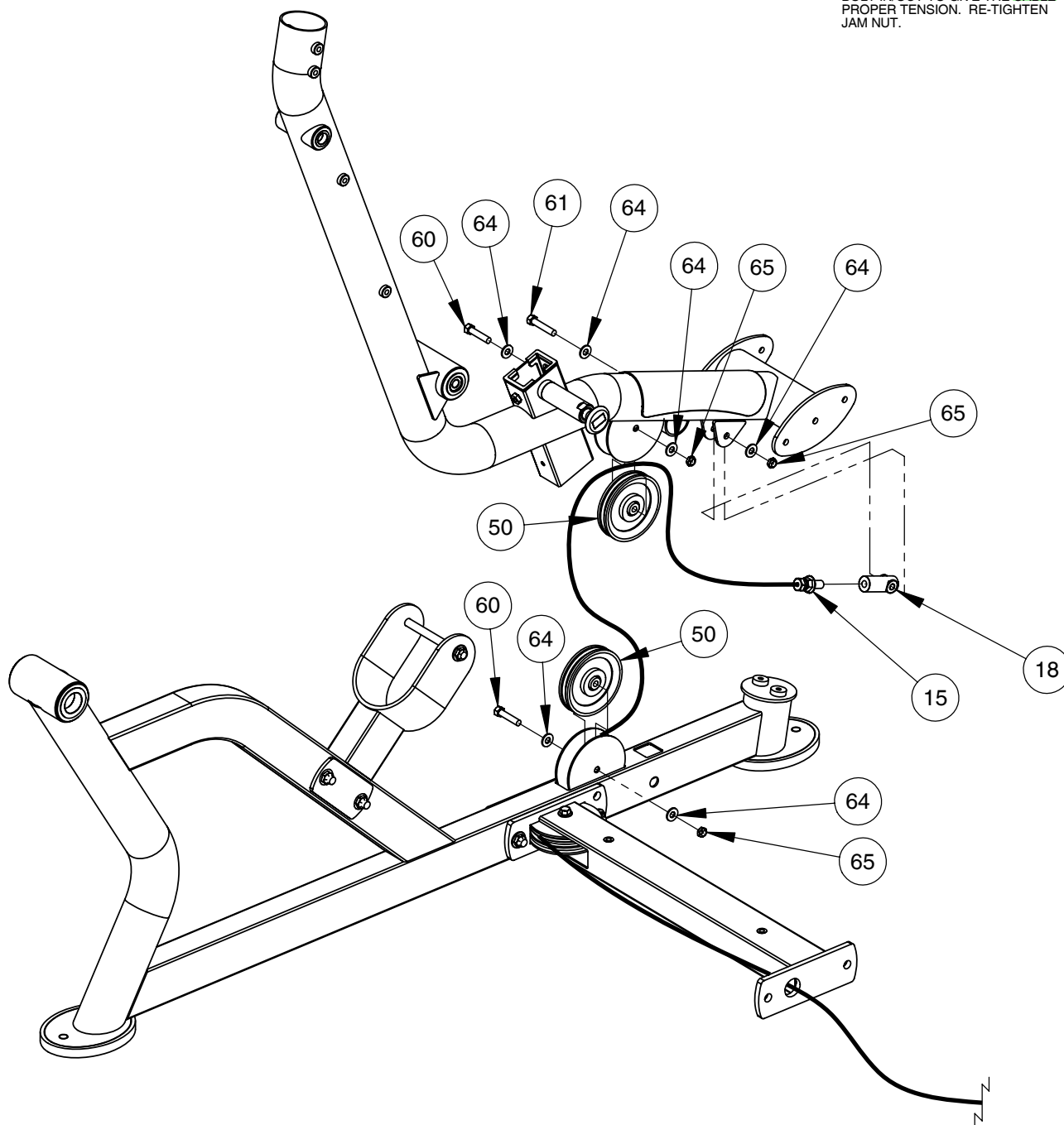

OWNER'S MANUAL

FRAME ASSEMBLY HEAVY CABLING OPTION

WARNING - CABLE BOLT MUST BE THREADED A MINIMUM OF 3/8" WITH JAM NUT TIGHTENED SECURELY TO ENSURE PROPER CONNECTION.

NOTE:

- WRENCH TIGHTEN ALL OTHER HARDWARE.
- INSTALL CABLE AND PULLEYS AT THE SAME TIME.
- SOME PARTS MAY HAVE BEEN REMOVED FOR CLARITY.

FINE TUNING:

LOOSEN JAM NUT AND THREAD BOLT IN/OUT TO GIVE THE CABLE PROPER TENSION. RE-TIGHTEN JAM NUT.

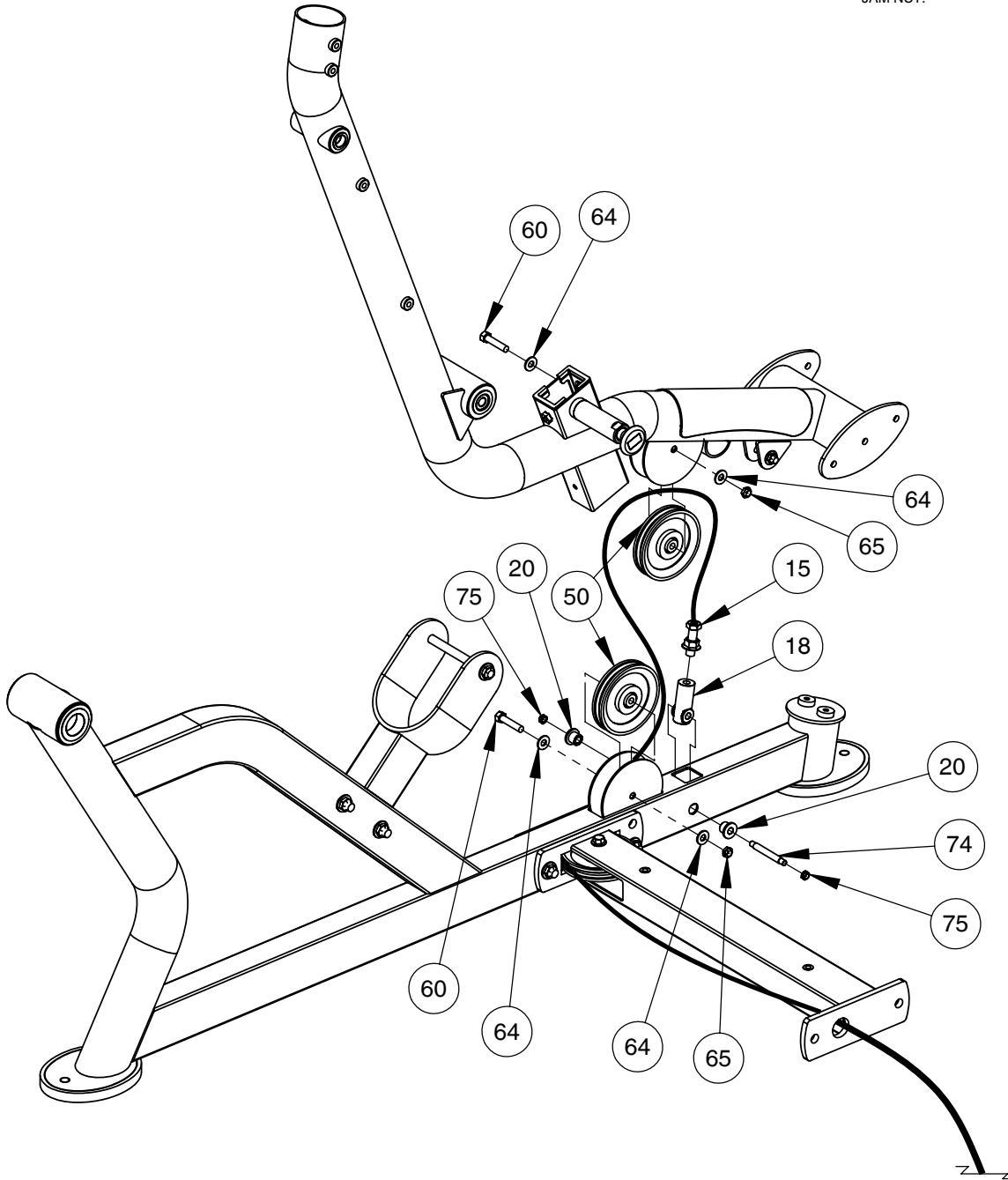

OWNER'S MANUAL

FRAME ASSEMBLY

- NOTE:
- WRENCH TIGHTEN HARDWARE.
 - SOME PARTS HAVE BEEN REMOVED FOR CLARITY.
 - REPEAT STEPS FOR OPPOSITE SIDE .

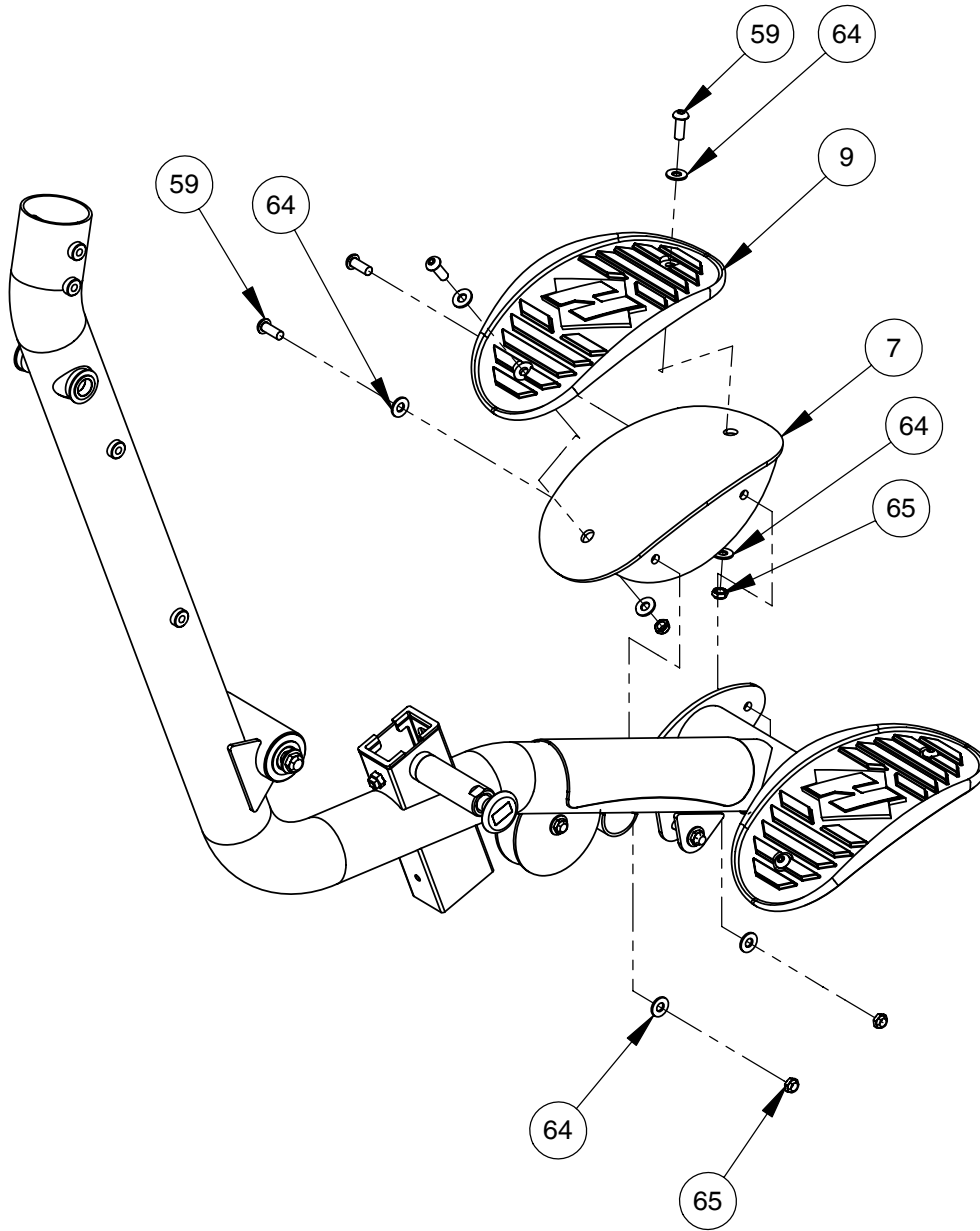

OWNER'S MANUAL

FRAME ASSEMBLY

- NOTE:
- WRENCH TIGHTEN HARDWARE(54 & 55) THEN LOOSEN NUT JUST ENOUGH FOR (2,3,& 5) TO PIVOT FREELY.
 - WRENCH TIGHTEN ALL HARDWARE FROM PREVIOUS STEPS.
 - SOME PARTS MAY HAVE BEEN REMOVED FOR CLARITY.

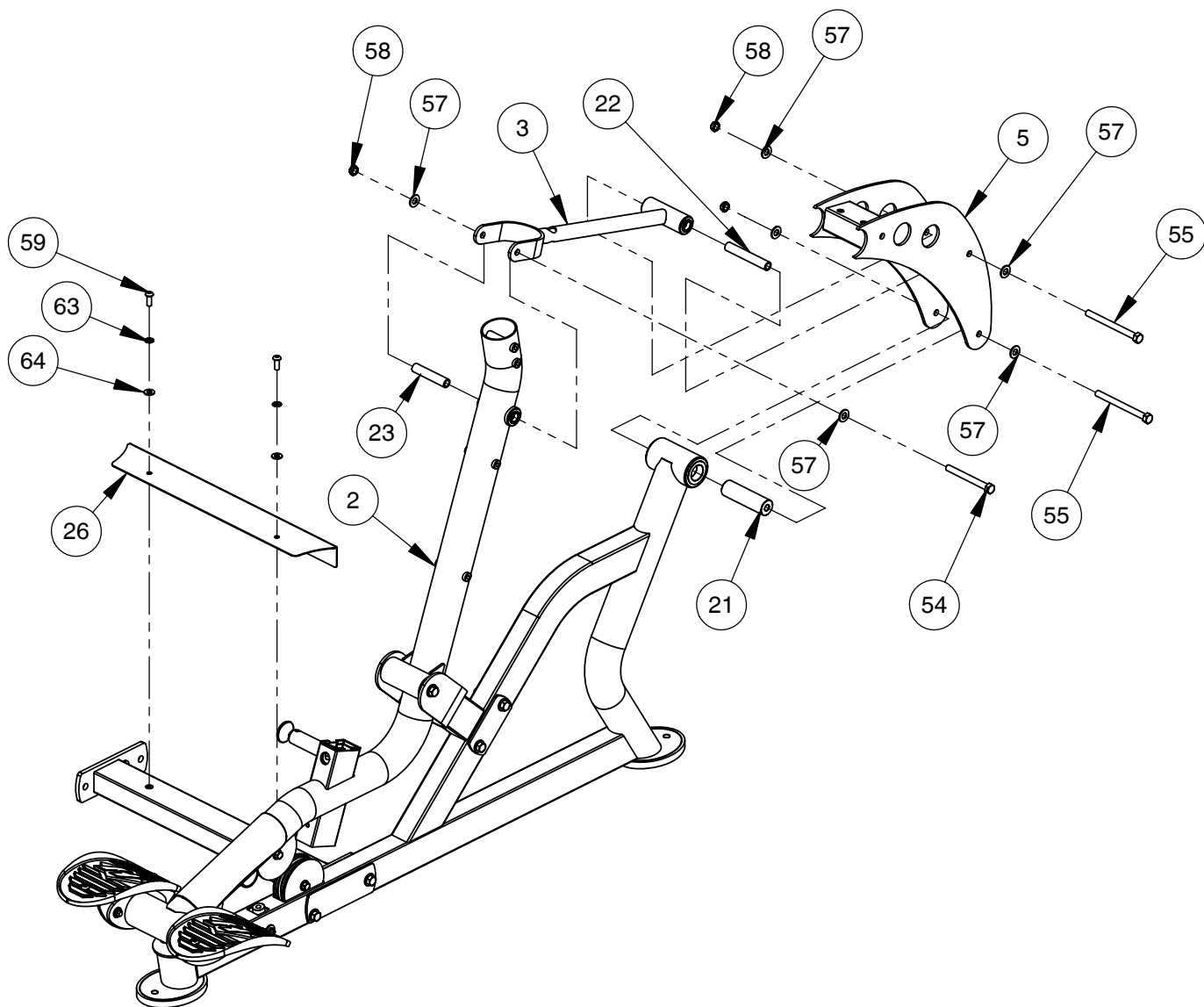

OWNER'S MANUAL

FRAME ASSEMBLY

- NOTE:
- WRENCH TIGHTEN HARDWARE.
 - WRENCH TIGHTEN ALL HARDWARE FROM PREVIOUS STEPS.
 - SOME PARTS MAY HAVE BEEN REMOVED FOR CLARITY.

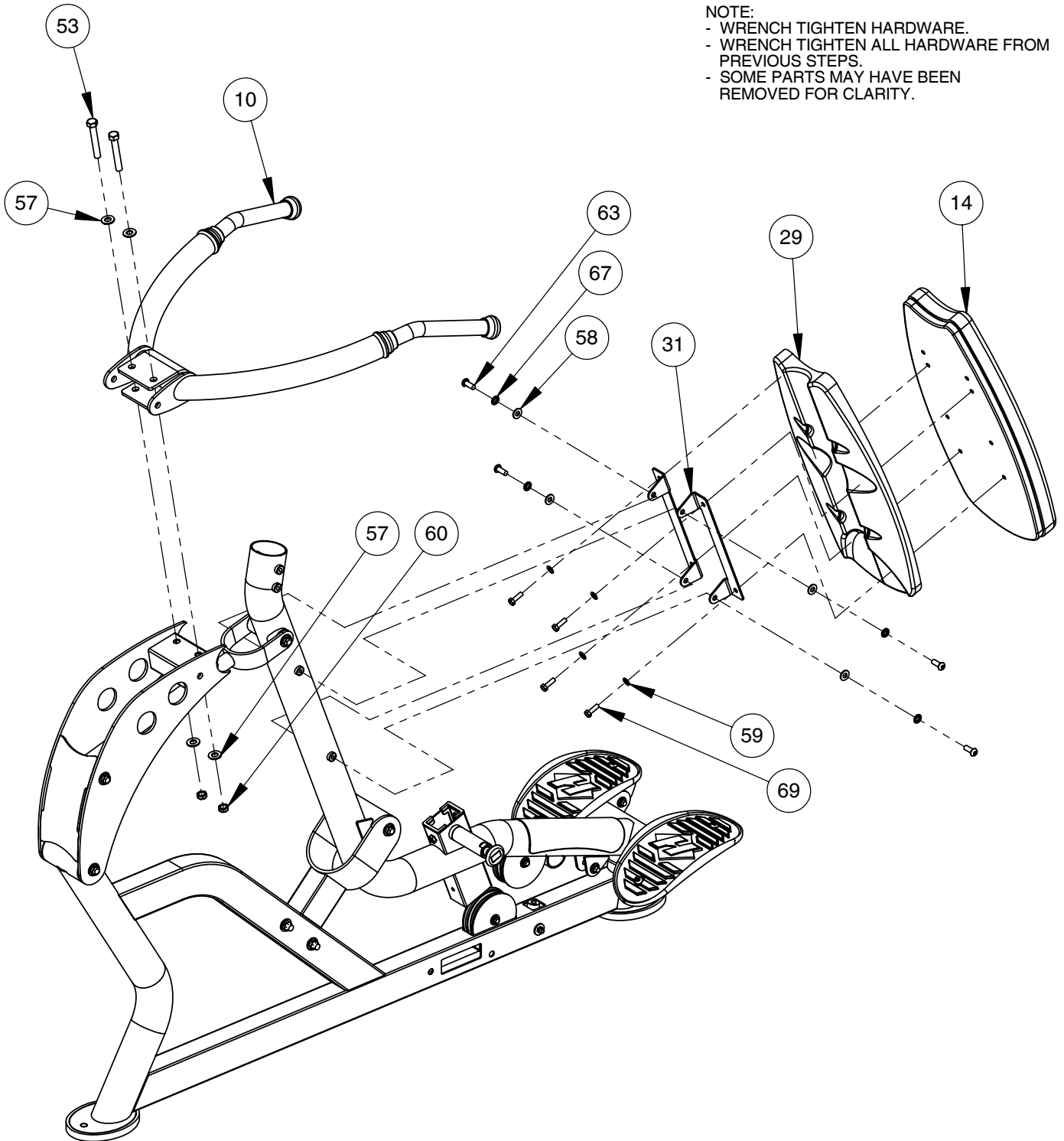

OWNER'S MANUAL

FRAME ASSEMBLY

NOTE:
- WRENCH TIGHTEN HARDWARE.
- HAND TIGHTEN HARDWARE.

STOP

WHEN FINISHED WITH THIS STEP
PLEASE SEE ROC-IT WEIGHT
CAGE MANUAL FOR FINAL ASSEMBLY.

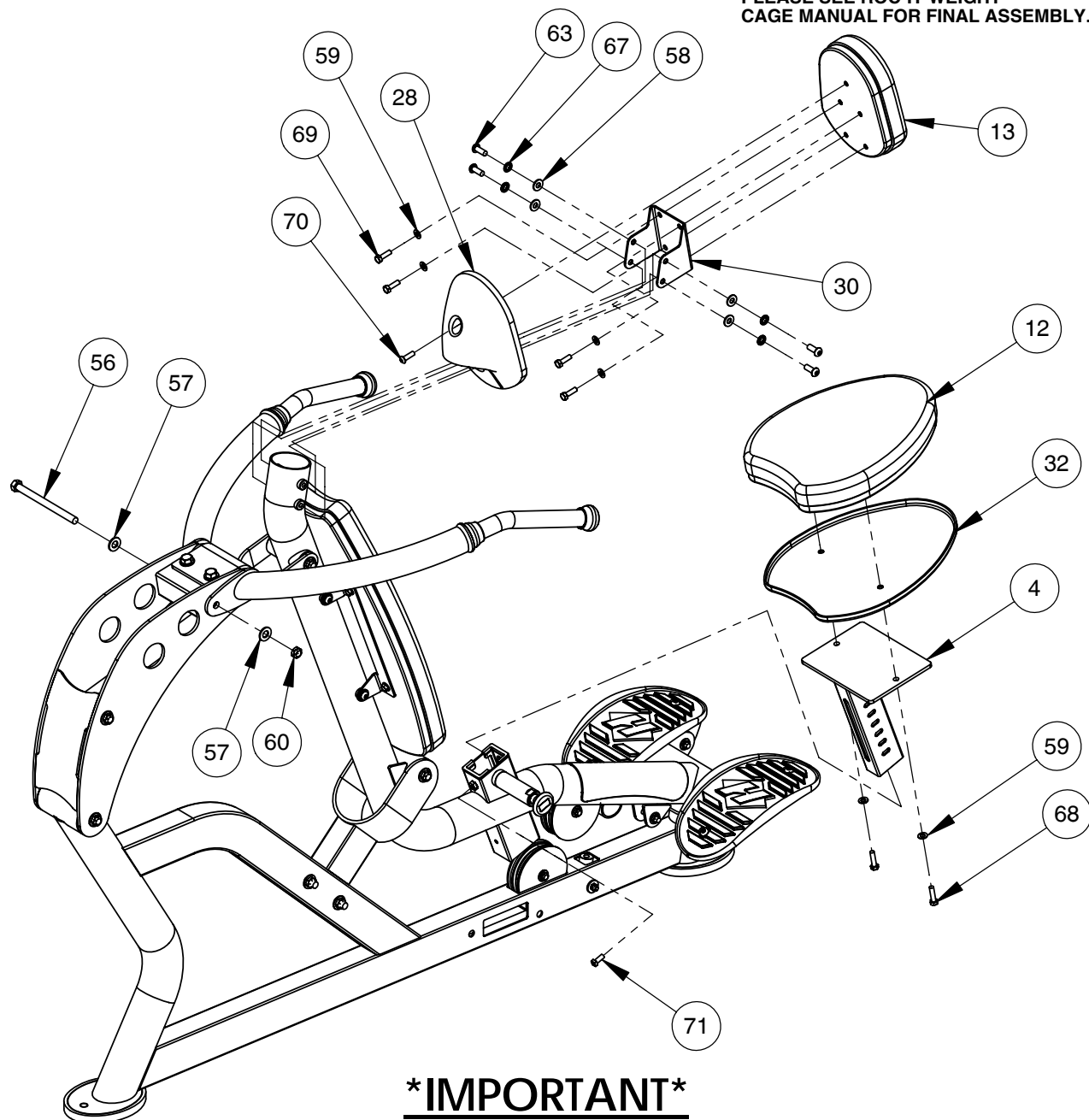

IMPORTANT

NOW THAT THE RS-1501 IS COMPLETELY ASSEMBLED TAKE TIME TO ASSURE THAT YOUR UNIT IS ASSEMBLED SQUARE AND PERPENDICULAR. USE A LEVEL TO CHECK THAT THE GUIDE RODS ARE PERPENDICULAR IN BOTH DIRECTIONS. IF THEY ARE NOT PERPENDICULAR IN BOTH DIRECTIONS, IT WILL BE NECESSARY TO LOOSEN SOME FRAME HARDWARE TO RE-ALIGN THE FRAME AND RETIGHTEN BOLTS.

OWNER'S MANUAL

PRE-ASSEMBLY

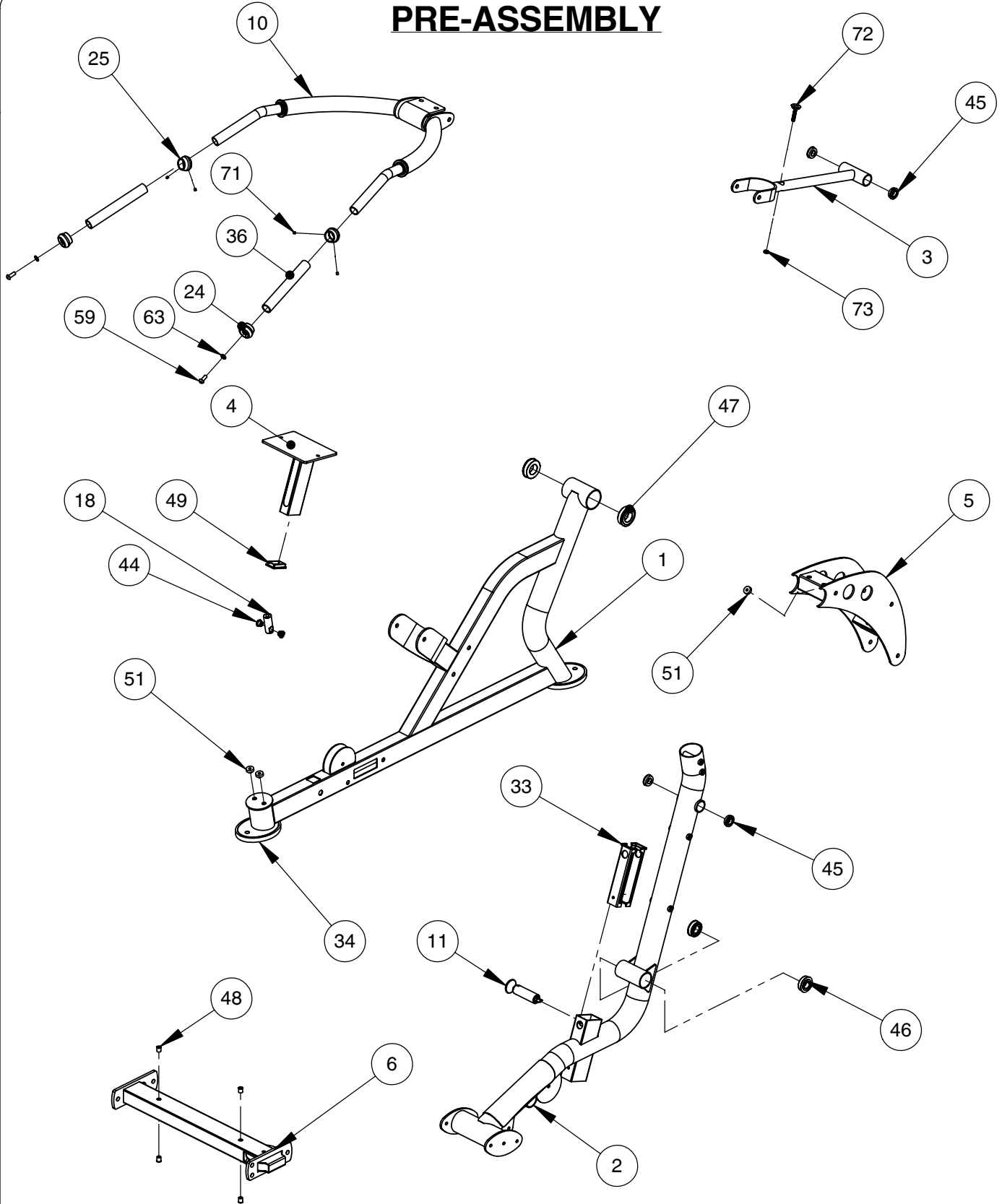

OWNER'S MANUAL

DECAL PLACEMENT

NOTE:

- ALL DECALS ARE CENTERED UNLESS OTHERWISE STATED.
- SOME PARTS MAY HAVE BEEN REMOVED FOR CLARITY.

* FOR CIRCUIT STACK, USE ITEM #38.
FOR COMPETITION STACK, USE ITEM #77.

** FOR CIRCUIT STACK, USE ITEM #41.
FOR COMPETITION STACK, USE ITEM #78

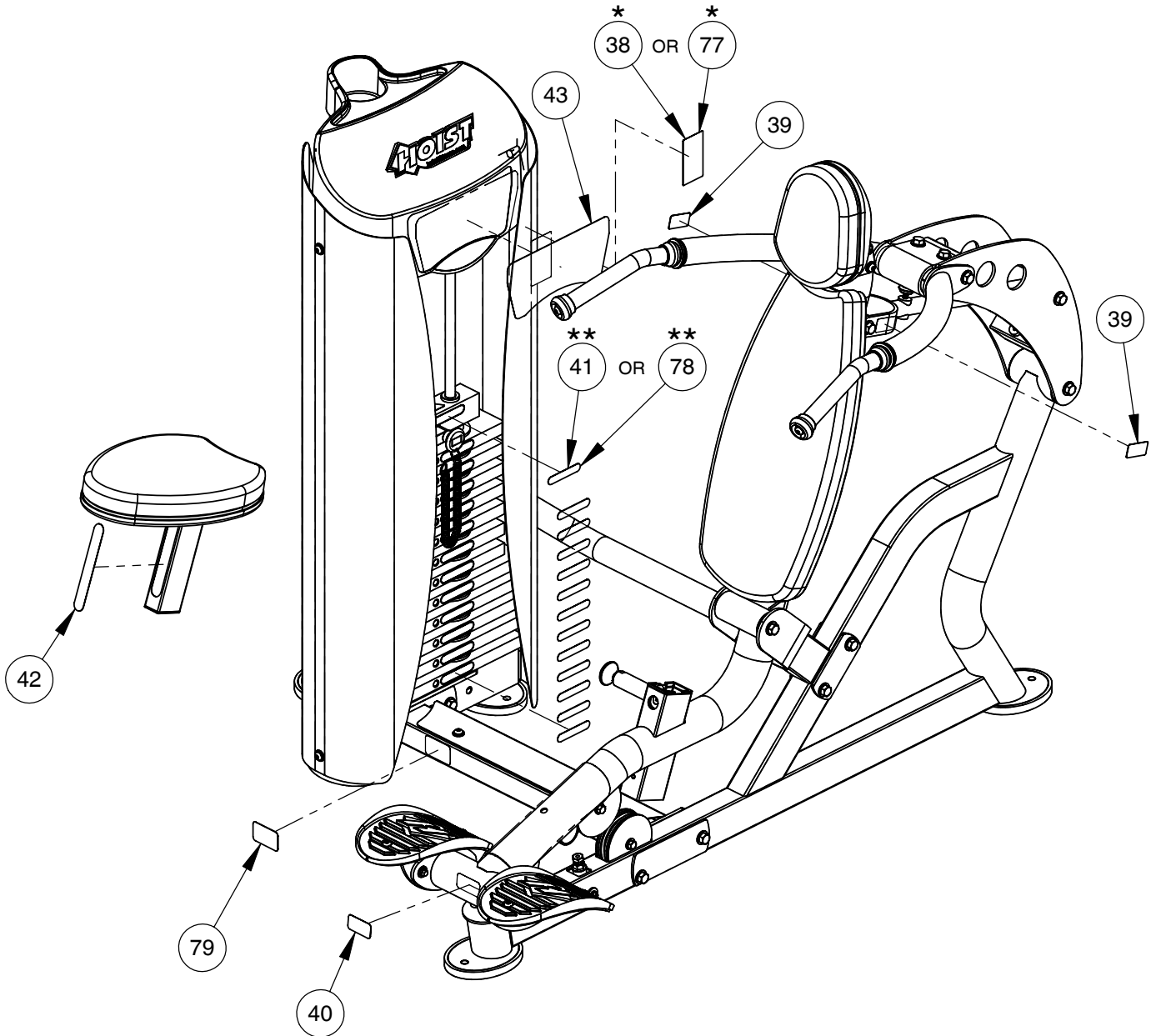

OWNER'S MANUAL

DECAL REFERENCE

ROC-IT™
SELECTORIZED

SHOULDER PRESS
RS-1501

SHOULDERS

CAUTION

- 1 Your seat is designed to move as you exercise.
- 2 Keep feet on footrests and hands on handles at all times.
- 3 Do not enter or exit the machine unless it is stationary.

INSTRUCTIONS

- 1 **ADJUST** seat so handles are at shoulder level.
- 2 Sit with feet on footrests.
- 3 Grasp handles and push hands up. **EXERCISE.**
- 4 Slowly return to the start position.

START **EXERCISE**

021-0013304

1 **5** **9**

2 **6** **10**

3 **7** **11**

4 **8** **12**

MAX

021-0003422

1 **7** **13**

2 **8** **14**

3 **9** **15**

4 **10** **16**

5 **11** **17**

6 **12** **18**

021-0003515

HOIST®

1-800-548-5438
www.hoistfitness.com
SERIAL # 00-00-000000

SERIAL # DECAL

021-0004032

WARNING
PINCH POINTS

021-0003341

CAUTION
MOVING PARTS

021-0003093

(kg)	SHOULDER PRESS	(lbs)
18	1	39
19	2	42
21	3	45
22	4	49
24	5	52
25	6	55
27	7	59
28	8	62
30	9	66
32	10	70
34	11	74
35	12	78
37	MAX	82

021-0003411

(kg)	RS-1501 SHOULDER PRESS COMPETITION	(lbs)
20	1	45
22	2	49
25	3	55
28	4	62
31	5	69
34	6	76
38	7	83
41	8	90
44	9	97
47	10	104
50	11	111
54	12	118
57	13	125
60	14	132
63	15	139
66	16	146
69	17	153
73	18	160

021-0003623

OWNER'S MANUAL

PART LIST

NOTE: SOME OF THE PARTS MAY COME PRE-INSTALLED

ITEM NO.	PART NUMBER	DESCRIPTION	QTY.
1	026-01X3233	BASE ASSEMBLY	1
2	026-01X3232	MAIN ASSEMBLY	1
3	026-01X2390	LINKAGE ASSEMBLY	1
4	026-01X2387	SEAT PAD ASSEMBLY	1
5	026-01X3273	PRESS ARM ASSEMBLY	1
6	026-01X2377	CROSS MEMBER ASSEMBLY	1
7	026-01X2975	FOOT PLATE MOUNT ASSEMBLY	2
8	026-01X3271	CROSS BAR ASSEMBLY	1
9	026-01X2402	FOOT PLATE ASSEMBLY	2
10	026-01X3272	PRESS HANDLE ASSEMBLY	1
11	026-01X2849	RACHET PULL-PIN ASSEMBLY	1
12	022-01PD2054-A	SEAT PAD ASSEMBLY	1
13	022-01PD2055	UPHOLSTERED HEAD PAD	1
14	022-01PD2058	UPHOLSTERED BACK PAD	1
15	010-01C0356	CABLE ASSEMBLY RS-1501 - 136 1/16" LG.	1
16	026-01F0256	BACKING PLATE	1
17	026-01F0289	FLANGE	1
18	026-01M1103	THREADED CABLE ANCHOR Ø1.00" O.D X 2.50" LG.	1
19	026-01M0660	SHAFT Ø1.00" O.D. X Ø .52" I.D. X 4.69" LG.	1
20	026-01M0760	HEAVY FLANGED SPACER: Ø.67" O.D. X Ø.39" I.D. X .50" LG.	2
21	026-01M0920	SHAFT: Ø 1.38" O.D. X Ø.52" I.D. X 4.69" LG.	1
22	026-01M0925	SHAFT Ø.75" O.D. X Ø.52" I.D X 4.69" LG.	1
23	026-01M0927	SHAFT Ø.75" O.D. X Ø.52" I.D. X 3.82" LG.	1
24	026-01M0932	END CAP: ALUMINIUM Ø1.25" ID	2
25	026-01M0933	ALUMINUM RING: Ø1.25" ID	2
26	026-01P2478	CABLE SHIELD	1
27	026-01P2653	'H' PLATE	1
28	022-01PD2055-5	PLASTIC HEAD PAD BACKING	1
29	022-01PD2058-5	PLASTIC BACK PAD BACKING	1
30	026-01P2920	HEAD BRACKET MOUNT	1
31	026-01P2925	PAD MOUNT BRACKET	2
32	022-01PD2054-5	SEAT PAD PLASTIC BACKING	1
33	026-01PL0125-125	E-Z GLIDE PLASTIC SLEEVE	2
34	026-01PL2122	OVAL-SHAPED RUBBER FOOT	2
35	026-01PL2197	PLASTIC SCUFF GUARD 11.05" LG.	1
36	026-01PL0206-29	GRIP Ø 1.00" X 9.25" LG.	2
37	ROC-IT WEIGHT CAGE	ROC-IT WEIGHT CAGE	1
38	021-0003411	DECAL ROC-IT WEIGHT RATIO SHOULDER PRESS (CIRCUIT)	1
39	021-0003341	DECAL PINCH POINT 1.07" X 2.13" (HORIZONTAL)	2
40	021-0003093	DECAL MOVING PARTS 1.20" X 2.38" (HOR)	1

OWNER'S MANUAL

PART LIST

NOTE: SOME OF THESE PARTS MAY COME PRE-INSTALLED

ITEM NO.	PART NUMBER	DESCRIPTION	QTY.
41	021-0003422	DECAL ROC-IT WEIGHT STACK (1-12)	1
42	021-0004032	DECAL ADJUST 1-7 VERTICAL TXT.	1
43	021-0013304	PLACARD ROC-IT-501 SHOULDER PRESS	1
44	014-0101020	BUSHING: OILITE FLANGE Ø.63" O.D. X Ø.38" I.D. X .50" LG.	2
45	014-0005001	BEARING: (SMALL) Ø1.37" O.D. X Ø.75" I.D.	4
46	014-0009007	BEARING: FLANGED Ø2.00" O.D. X Ø1.00" I.D.	2
47	014-0012010	BEARING: FLANGED BEARING Ø2.50" O.D. X Ø1.39" I.D.	2
48	014-0014002	3/8-16 FLUSH MOUNT INSERT	4
49	016-0001003	END CAP 1.50" X 2.50" (BLACK)	1
50	018-0001003	CABLE PULLEY: Ø4.50"	3
51	019-0001001	PLUG BUMPER	3
52	011-0101047	1/2"-13UNC X 1.50" BHCS (WZ)	2
53	011-0107034	1/2"-13UNC X 3.25" HHB (WZ)	8
54	011-0407055	1/2"-13UNC X 4.75" HHB (WZ)	1
55	011-0107036	1/2"-13UNC X 5.75" HHB (WZ)	3
56	011-0107027	1/2"-13UNC X 6.50" HHB (WZ)	1
57	013-0102003	1/2" X 27mm SAE FLAT WASHER (WZ)	30
58	012-0304011	1/2"-13 UNC THIN NYLOCK NUT (WZ)	15
59	011-0101026	3/8"-16UNC X 1.00" BHCS (WZ)	20
60	011-0407027	3/8"-16UNC X 1.75" HHB (WZ)	2
61	011-0407058	3/8"-16UNC X 2.00" HHB (WZ)	1
62	011-0107009	3/8"-16UNC X 2.50" HHB (WZ)	1
63	013-0102022	3/8" INTERNAL LOCK WASHER	12
64	013-0402007	3/8" X 22mm FLAT WASHER (WZ)	34
65	012-0104008	3/8"-16 UNC THIN NYLOCK NUT (WZ)	12
66	011-0107011	5/16"-18UNC X 1.25" HHB (WZ)	2
67	011-0101030	5/16"-18UNC X 1.00" BHCS (WZ)	1
68	011-0107029	5/16"-18UNC X 1.00" HHB (WZ)	8
69	013-0302008	5/16" SAE FLAT WASHER (WZ)	10
70	011-0311013	3/8-16UNC X .75" SQUARE HEAD (WZ)	1
71	011-0111008	SET SCREW: 1/4"-28 X .25" LG. (WZ)	4
72	020-0014027	ADJUSTABLE STOP	1
73	012-0305003	3/8"-16UNC JAM NUT (WZ)	1
74	026-01M1137	CABLE ANCHOR SHAFT Ø.38"O.D. X 3.0625" LG.	1
75	012-0102006	5/16"-18UNC THICK NYLOCK NUT (WZ)	2
76	026-01PL2200	PINETREE PLUG	2
77	021-0003623	DECAL ROC-IT WEIGHT RATIO SHOULDER PRESS (COMPETITION)	1
78	021-0003515	DECAL ROC-IT WEIGHT STACK (1-18)	1
79	SERIAL # DECAL	DECAL HOIST SERIAL # 1.63" X 2.63"	1

OWNER'S MANUAL

BZ = Black Zinc

WZ = White Zinc

HHB = Hex Head Bolt

FHCS = Flat Head Cap Screw

BHCS = Button Head Cap Screw

SHCS = Socket Head Cap Screw

SHSS = Socket Head Shoulder Screw

OWNER'S MANUAL

BOLT SIZING CHART

5/16" HHB

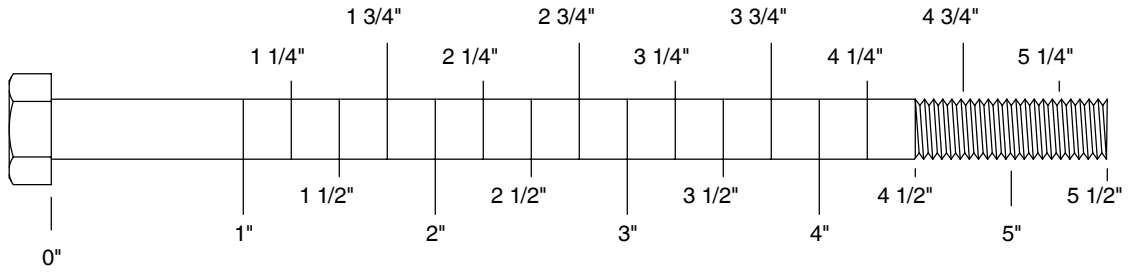
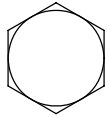

3/8" HHB

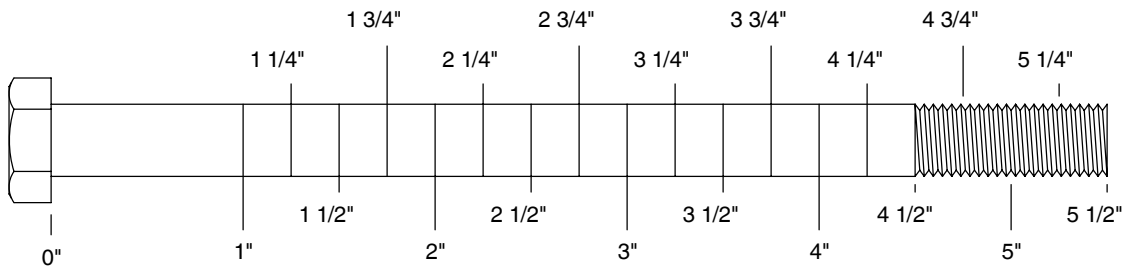
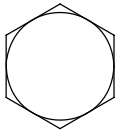

1/2" HHB

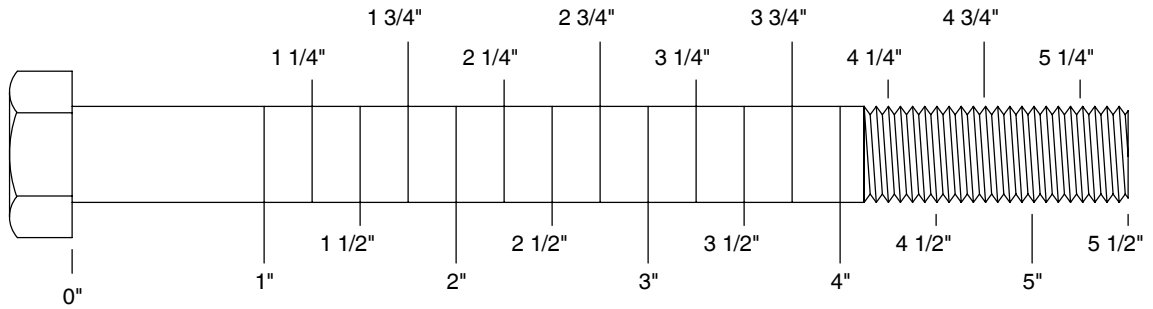
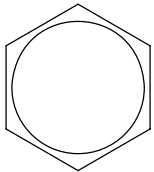

1/2" SHSS

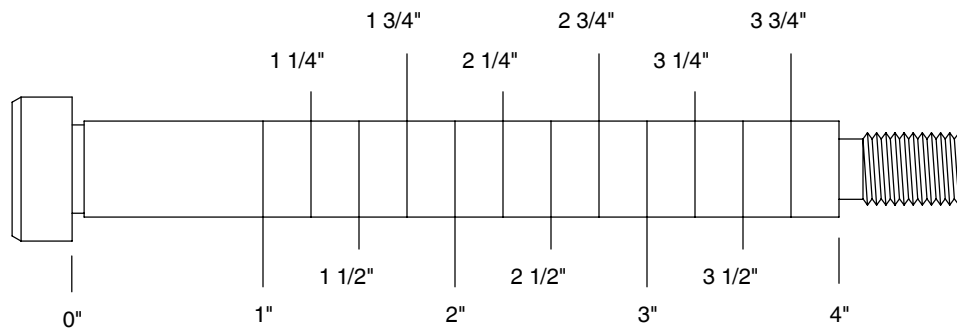
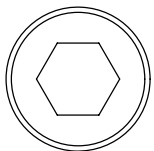

OWNER'S MANUAL

BOLT SIZING CHART (CONTINUED)

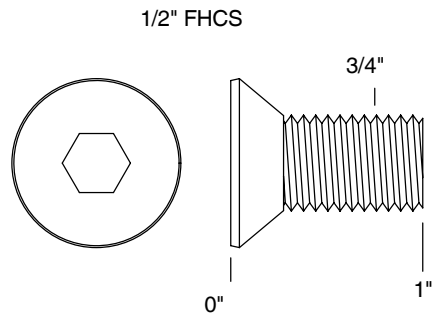
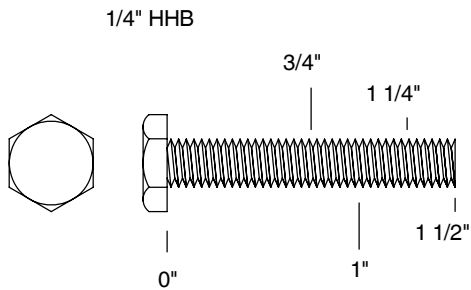
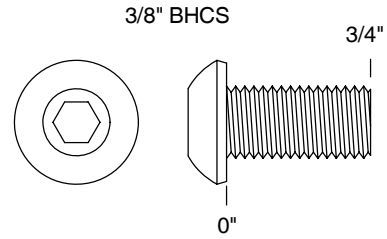
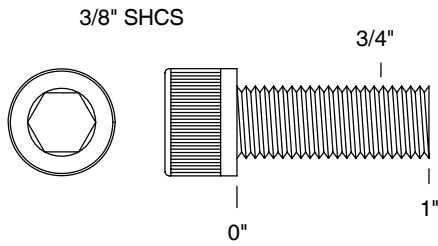
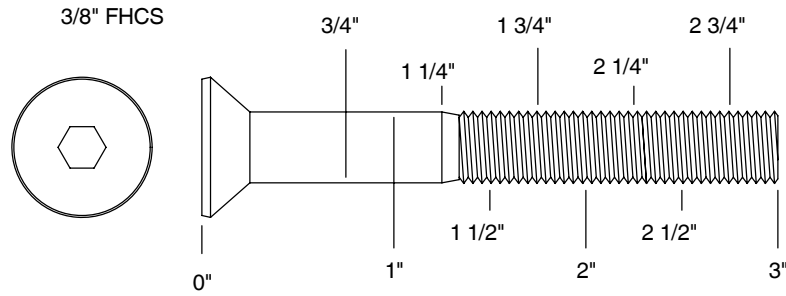

OWNER'S MANUAL

WASHER SIZING CHART

013-0002003
1/4"
FLAT WASHER
SMALL, SAE, 13mm

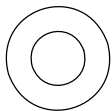

013-0102004
5/16"
FLAT WASHER
LARGE, USS, 22mm

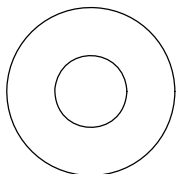

013-0002004
3/8"
FLAT WASHER
SMALL, SAE, 21mm

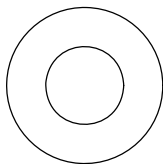

013-0402005
3/8"
FLAT WASHER
LARGE, USS, 25mm

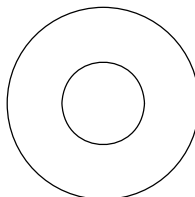

013-0102003
1/2"
FLAT WASHER
SMALL, SAE, 27mm

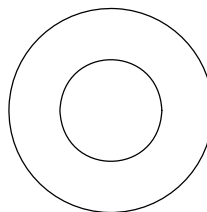

013-0102026
1/2"
FLAT WASHER
LARGE, USS, 34mm

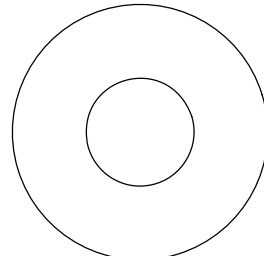

013-0102028
3/8"
CURVED WASHER

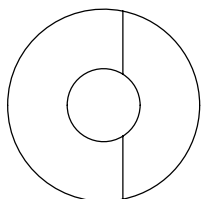

013-0402007
3/8"
FLAT WASHER
22mm O.D.

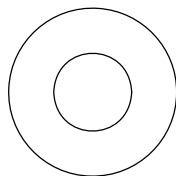

013-0102019
1/4"
LOCK WASHER



013-0102020
3/8"
LOCK WASHER

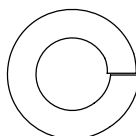

013-0102018
1/2"
LOCK WASHER

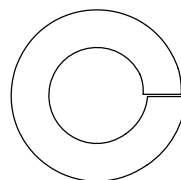

014-0018001
1/2" LONG
SPACER



026-01M0238
2" ALUMINUM
FLATHEAD CAP

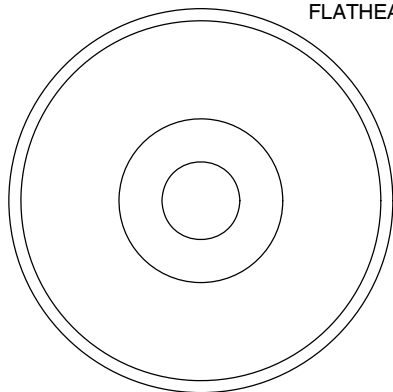

016-0009003
1" SHIM WASHER

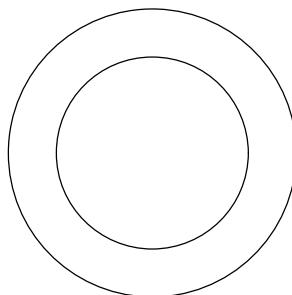

013-0003002
3/8" FENDER WASHER

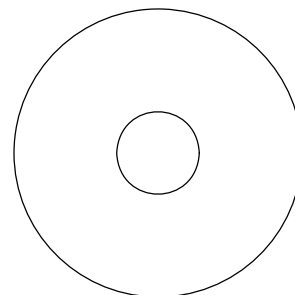

013-0003004
1 1/16"
FENDER WASHER

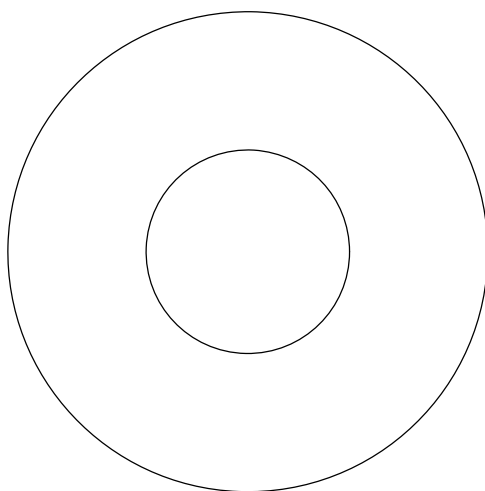

026-01PL151
PLASTIC 1 1/16"
FENDER WASHER

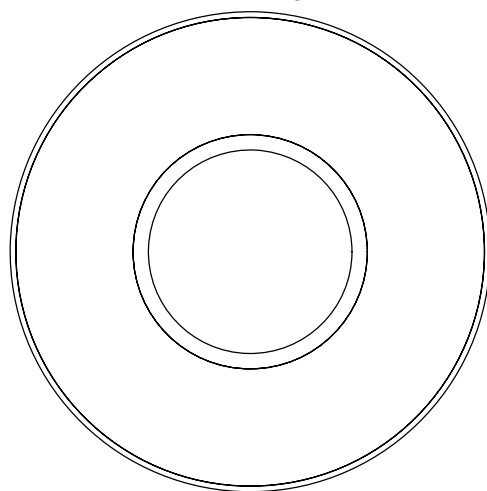

014-0018002
1" LONG
SPACER

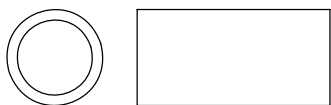

OWNER'S MANUAL

WASHER SIZING CHART (CONTINUED)

026-01M0211
1/4" LONG
FLANGED SPACER

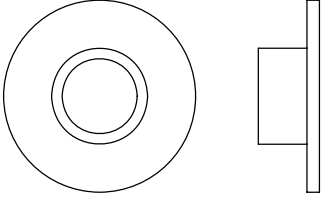

026-01M0198
1/2" LONG
FLANGED SPACER

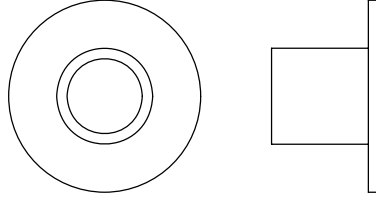

026-01M0760
1/2" LONG HEAVY
FLANGED SPACER

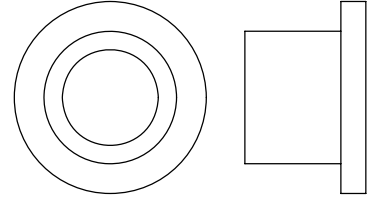

026-01M211T
1/4" LONG HEAVY
FLANGED SPACER

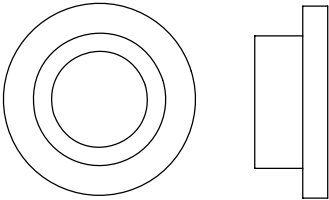

026-01M0532
11/16" LONG HEAVY
FLANGED SPACER

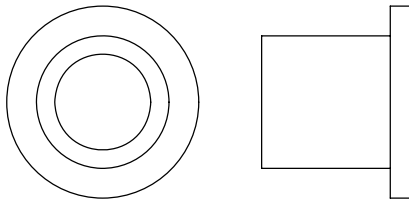

026-01M0551
1" LONG HEAVY
FLANGED SPACER

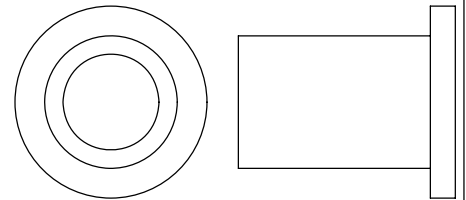

026-01M0788
.81" LONG HEAVY
FLANGED SPACER

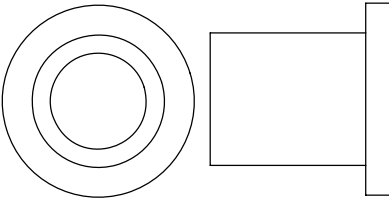

026-01M0780
.65" LONG HEAVY
FLANGED SPACER

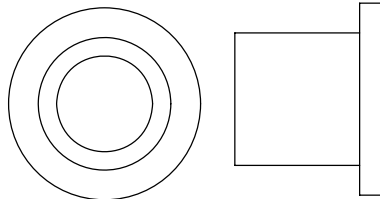

026-01M0761
1 11/16" LONG HEAVY
FLANGED SPACER

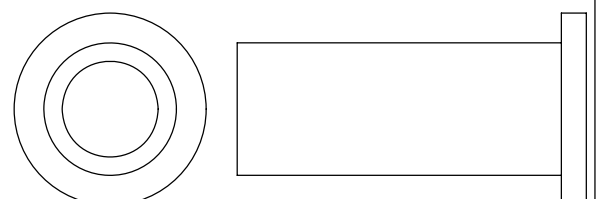

026-01M0789
.44" LONG HEAVY
FLANGED SPACER

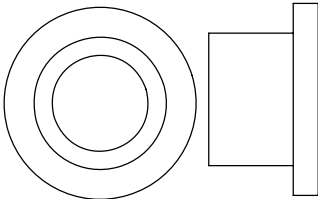

026-01M0762
1 1/2" LONG HEAVY
FLANGED SPACER

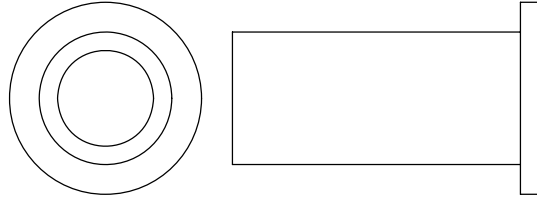

026-01M0768
1 1/4" LONG HEAVY
FLANGED SPACER

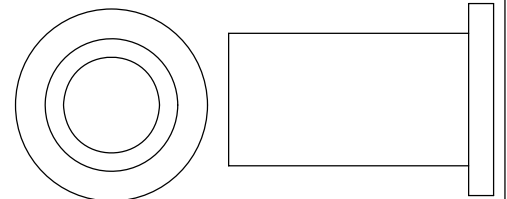

026-01M0600
.625" LONG
FLANGED SPACER

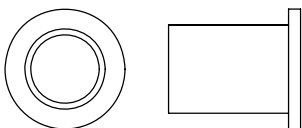

026-01M0240
1 3/8" ALUMINUM
FLATHEAD CAP

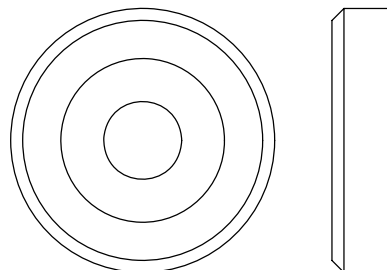

026-01M0239
1 5/8" ALUMINUM
FLATHEAD CAP

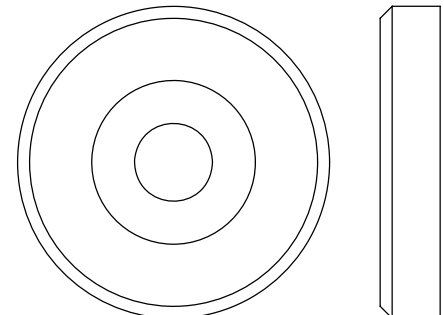

OWNER'S MANUAL

MAINTENANCE SCHEDULE

ROUTINE	COMMERCIAL MAINTENANCE	HOME MAINTENANCE	LATEST DATE ENTRY																	
Inspect; Links, Pull Pins, Snap Locks, Swivels, Weight Stack Pins	DAILY	WEEKLY																		
Clean; Upholstery	DAILY	WEEKLY																		
Inspect; Cables or Belts and their tension	DAILY	WEEKLY																		
Inspect; Accessory Bars, and Handles	WEEKLY	3 MONTHS																		
Inspect; All Decals	WEEKLY	3 MONTHS																		
Inspect; All Nuts and Bolts, Tighten if needed	WEEKLY	3 MONTHS																		
Inspect; Anti-Skid Surface	WEEKLY	3 MONTHS																		
Clean & Lubricate; Guide Rods with a Teflon (PTFE) based lubricant (Superlube)	MONTHLY	3 MONTHS																		
Lubricate; Seat Sleeves, Turcite Bushings, Linear Bearing	MONTHLY	3 MONTHS																		
Clean and Wax; All Glossy Finishes	6 MONTHS	YEARLY																		
Repack with Grease; Linear Bearings	6 MONTHS	YEARLY																		
Replace; Cables, Belts and Connecting Parts	YEARLY	3 YEARS																		

*Your equipment comes with a commercial maintenance decal.
For personal, in home use, please follow the home maintenance schedule listed above.*

OWNER'S MANUAL

HOIST FITNESS SYSTEMS **GENERAL MAINTENANCE INFORMATION**

Links, Pull-Pins, Snap Hooks, Swivels, Weight Stack Pins:

- Check all pieces for signs of visible wear or damage.
- Check springs in snap hooks and pull-pins for proper tension and alignment.
- If the spring sticks or has lost its rigidity, replace it immediately.

Upholstery:

- To ensure prolonged upholstery life and proper hygiene, all upholstered pads should be wiped down with a damp cloth after every workout.
- Periodically take the time to use a mild soap or an approved vinyl upholstery cleaner to deter the onset of cracking or drying. Avoid using any abrasive cleaners or cleaners not intended for use on vinyl.
- Replace ripped or worn upholstery immediately.
- Keep sharp or pointed objects clear of all upholstery.

Decals:

- Inspect and familiarize yourself with any safety warnings or other user information posted on each decal.

Nuts and Bolts:

- Inspect all nuts and bolts for any loosening and tighten if needed.
- Go through a re-tightening sequence periodically to ensure that all hardware is tensioned proper.

Anti-Skid Surfaces:

- These surfaces are designed to supply secure footing and need to be replaced if they appear worn or become slippery.

Belts and Cables:

- Hoist uses only high quality belt, and mil-spec cables.
- Visually inspect the belts and cables for fraying, cracking, peeling or discoloration.
- While the machine is not in use, carefully run your fingers along the belt or cable to feel for thinning or bulging areas.
- Replace belts and cables immediately at the first signs of damage or wear. Do not use equipment until belts or cables have been replaced.

OWNER'S MANUAL

GENERAL MAINTENANCE INFORMATION

(CONTINUED)

Belt and Cable Tension:

- Referring to the Owners Manual, when belts or cables are used check all bolts attachments to be sure they are properly attached.
- Check slack in cables and re-adjust cable tension if needed.

Seat Sleeves, Guide Rods:

- Wipe down adjusting tubes with a dust free rag before applying lubricant.
- Lubricate seat sleeves and Guide Rods with a Silicon or Teflon based lubricant spray.

Linear Bearings:

- Referring to the Owners Manual carefully disassemble the bearing from its housing and place a finger full of light grease (lithium, super lube, etc.) into the inside of the bearing. Using your finger, press the grease into the ball-bearings and their tracks. repeat until the ball-bearing tracks are full of grease. Insert the shaft back into the bearing and wipe off excess grease.

PLEASE KEEP THIS FOR YOUR RECORDS

OWNER'S MANUAL

*****THIS PAGE WAS INTENTIONALLY LEFT BLANK.*****

OWNER'S MANUAL

WEIGHT TRAINING TIPS

Always consult your physician before starting any exercise program.

To be successful in your exercise program, it is important to develop an understanding of the basic principles of strength training. Now that you have your RS-1501 HOIST® Fitness System, it is only natural that you want to get started immediately. First, determine a set of realistic goals and objectives for yourself. By deciding on an exercise plan that is right for you prior to starting, you will contribute significantly to your success.

Warm up properly before engaging in weight resistance training. Stretching, yoga, jogging, calisthenics or other cardiovascular exercise can help prepare your body for the heavier workload of lifting weights.

Learn how to perform the exercise correctly before using heavy weight. Correct form is important to avoid injury and to ensure that you work the proper muscle groups.

Know your limitations. If you are new to weight training or are embarking on an exercise regimen after a long layoff, start slowly and build foundational strength over a longer period of time.

Pay attention to your breathing. Exhale when you exert is a general rule of thumb. Never hold your breath.

To gain maximum results and avoid possible injury, consult a fitness professional to develop your complete exercise program.

Enjoy your RS-1501 HOIST Fitness System!

OWNER'S MANUAL

WEIGHT RATIOS

CIRCUIT STACK

(kg)	SHOULDER PRESS	(lbs)
18		39
19		42
21		45
22		49
24		52
25		55
27		59
28		62
30		66
32		70
34		74
35		78
37		82

COMPETITION STACK

(kg)	RS-1501 SHOULDER PRESS COMPETITION	(lbs)
20		45
22		49
25		55
28		62
31		69
34		76
38		83
41		90
44		97
47		104
50		111
54		118
57		125
60		132
63		139
66		146
69		153
73		160

001-000000 Rev A GOMP

The above chart shows the standard weight stack for this unit. The weights listed are approximate. HOIST reserves the right to modify the machine without prior notice.

OWNER'S MANUAL

HOIST FITNESS SYSTEMS **LIMITED LIFETIME WARRANTY**

Hoist Fitness Systems warrants this product to the **original purchaser** to be free from defects in workmanship and/or materials under normal use or service. If at any time a component part is defective, Hoist Fitness Systems shall repair or replace it (at Hoist Fitness Systems option) within a reasonable period of time. This warranty does not cover costs of removal, transportation or reinstallation. This warranty shall not apply if the defect was caused by misuse, neglect or normal wear and tear.

WARRANTY CLAIMS. All claims require: Model number, Serial number, Date of installation, and any information supporting the existence of the alleged defect.

To complete Warranty Registration visit:
www.HOISTFITNESS.com
and click on the Warranty Registration link

Starting from the original date of purchase, normal wear and tear shall be considered as the following:

COMMERCIAL USE: All malfunctions of upholstery, grips, paint, and chrome that occur after one year; all malfunctions of electronic components, belts, or **cables** after one year; all malfunctions of pulleys, bearings, or bushings that occur after five years. The frame and all welded components are warranted for the life of the product.

HOME USE: All malfunctions of grips, paint, and chrome that occur after ten years; all malfunctions of electronic components, belts, **cables**, or upholstery that occur after ten years; all malfunctions of pulleys, bearings, or bushings that occur after ten years. The frame and all welded components are warranted for the life of the product.

PLEASE NOTE THAT NOT ALL HOIST PRODUCTS ARE MADE FOR COMMERCIAL USE.

Refer to the instructions page of your owners manual or consult with you fitness product dealer to establish if a product is made for commercial use or not. Using a non-commercial product in a commercial setting can result in serious injury or death!

Hoist Fitness Systems sole responsibility shall be to repair or replace the component within the terms stated above. Hoist Fitness Systems shall not be liable for any loss or damage of any kind including any incidental or consequential damages resulting, directly or indirectly from any warranty expressed or implied or any other failure of this product.

WHAT IS NOT COVERED BY THIS WARRANTY

Hoist's sole obligation under this warranty is limited to either repair or replacement of parts, subject to the additions below. This warranty neither assumes nor authorizes any person to assume obligations other than expressly covered by this warranty.

NO CONSEQUENTIAL DAMAGES. Hoist is not responsible for economic loss; profit loss; or special, indirect, or consequential damages.

WARRANTY IS NOT TRANSFERABLE. This warranty is not assignable and applies only in favor of the original purchaser/user to whom delivered. Any such assignment or transfer shall void the warranties herein made and shall void all warranties, expressed, implied or statutory, except the one (1) and five (5) year warranties described above. These warranties are exclusive and in lieu of all other warranties, including implied warranty and merchantability or fitness for a particular purpose. There are no warranties which extend beyond the description on the face hereof.

TRANSPORTATION COSTS. Hoist will accept parts covered under this warranty freight collect, provided that shipment has received prior approval. Hoist is not responsible for any other transportation costs, but will ship freight collect parts either repaired or replaced under these warranties.

Hoist Fitness Systems
9990 Empire St. #130
San Diego, CA. 92126
(800)548-5438

PLEASE KEEP THIS FOR YOUR RECORDS